

# OPERATION MANUAL

**TØNSBERG AIRFIELD JARLSBERG  
AND JARLSBERG AIRSPORTS CENTER AS**



Rules and guidelines for the use of, and stay on, Tønsberg  
Airfield Jarlsberg

**Publisher: Jarlsberg Airsports Center**

Revision 4.9.5  
XX. Desember 2025

# **JLS AS**

## **Jarlsberg Airsports Center**

Flyplassveien 6 3170 Sem.

Phone: 94008400 Email: [bjorn.kristoffersen@trainor.no](mailto:bjorn.kristoffersen@trainor.no)

---

This document should be available to all users and guests at Tønsberg Airfield Jarlsberg. The document provides information and guidelines for the use of facilities and amenities on site. Use or stay beyond the guidelines given in this document are not allowed.

It should be obtained a permit from the Board of Jarlsberg Airsports Center for those activities or events that deviate from the norm described in this document.

It is the user's responsibility to stay informed and aware of the current guidelines and regulations for the use and stay at Tønsberg Airfield Jarlsberg

The assumptions and framework for its operations is provided by the Civil Aviation Authority and Tønsberg municipality operating permit and license.

Board of JLS Ltd as responsible management company has the overall responsibility for ensuring that these rules are met, and have the authority to take the measures that are necessary in this respect.

Board of JLS AS has delegated authority on all operational issues to the CEO / Airfield Manager who is executive authority in all buildings and the on the airfield in general.

---

## **General**

# **OPERATING MANUAL FOR TØNSBERG AIRFIELD JARLSBERG**

Operating Manual for Tønsberg Airfield Jarlsberg has been prepared by the Board of JLS AS. The Operations Manual is divided into two parts and contains rules and regulations that apply to all users of Jarlsberg Airfield as well as procedures and information which is of importance for the operation of the Airfield, buildings and installations

Part two is not implemented in this edition.

Questions and comments can be made to clubs operating Jarlsberg or to:

JLS AS Flyplassveien 6 3170 Sem.

web pages:

[www.jarlsbergluftsportssenter.no](http://www.jarlsbergluftsportssenter.no)

## REVISJONS HISTORY

4.9.5	12/25	Revised with new frequenz New LoA Torp ATC	FLPS		OK
4.9.2	12/20	Revised according to the Norwegian version.	FLPS		OK
4.9.1	--/--	No changes	FLPS	OK	OK
4.9	08/17	New consession and taxiway names	FLPS	OK	OK
4.8	01/17	Revised according to norwegian version	FLPS	OK	OK
4.7	01/16	New english version Draft	FLPS	OK	OK
<b>Rev.</b>	<b>Date</b>	<b>Text</b>	<b>Made by:</b>	<b>Approved JLS AS</b>	<b>Approved Airfield manager</b>

## **Welcome Jarlsberg Airsports Center**

### **Purpose and objective of the operation manual**

We hope you will enjoy yourself and feel at home at Tønsberg Airfield Jarlsberg. This operating manual is not designed to make your leisuretime bureaucratic and difficult. On the contrary, it is the objective of the operational rules to establish simple and secure operating conditions for all.

This can only be achieved when all users know what rules and regulations apply, and why these must be adhered to.

Therefore all active users of Jarlsberg must acknowledge that they have read, understood and agrees to comply with the rules at any time by signing the last page of this document.

Violation of the rules will not be accepted, which we hope everyone understands. This is necessary, if we are to operate Jarlsberg Airfield in a professional and safe way, to the benefit of both users as visitors.

Thank you for following the rules and help us enforce them.

Welcome to Tønsberg Airfield Jarlsberg -

Sincerely

Board of Jarlsberg Airsports Center

## Table of Contents:

<b>REVISJONS HISTORY</b> .....	4
<b>Operational policies and procedures</b> .....	8
1.0.1 General Rules .....	8
Conditions for use of Tønsberg Airfield Jarlsberg .....	9
1,1,1 Who can use Tønsberg Airfield Jarlsberg .....	9
1.1.2 Access and permission for use of the premises .....	9
1.1.3 Landing Fees .....	10
1.1.4 Conventions / Events .....	10
1.1.5 Definition of airshow .....	10
1.1.6 Payment of fees etc. ....	10
1.1.7 Exclusion .....	10
1.1.8 Insurance .....	10
1.1.9 How to register as a user .....	11
1.1.10 Airfield Information .....	12
1.1.11 Airspace .....	13
1.2.0 Parking .....	13
1.2.1 Motor vehicles .....	13
1.2.2 Parking and operation of aircraft on the ground .....	13
1.3.0 Rules for use of Jarlsberg .....	14
1.3.1 Additional Rules for operating light aircraft and Light sport aircraft .....	14
1.3.2 Additional rules for gliders .....	17
1.3.3 Additional Rules for helicopter flight .....	19
1.3.4 Additional Rules for skydiving .....	20
1.3.4.1 Checklist before parachuting .....	21
1.3.5 Additional Rules for model flying .....	23
11.4.0 Rules for club activities without a permanent base on Jarlsberg .....	24
1.4.1 Members of clubs without permanent base at ENJB .....	24
1.4.2 Other Activities .....	24
1.5.0 Reporting .....	24
1.5.1 Irregularities .....	24

1.5.2	Accidents.....	25
1.5.3	Accidents.....	25
1.6.0	Contingency plan .....	25
1.6.1	Introduction.....	25
1.6.4	Responsibilities and duties of CEO of Jarlsberg Airsports Center.....	27
1.7.0	Abbreviations .....	27
1.7.1	Definitions .....	28
1.8.0	Charts.....	29
1.8.1	VFR Approach chart ENJB / ENTO .....	30
1.8.2	Airfield chart .....	31
1.8.3	Jarlsberg modellflying area .....	32
1.8.4	Model flying area .....	33
1.8.5	Landing area parachuters .....	34
1.8.6	Airplane parking .....	35
1.8.7	Car Park .....	35
1.8.8	Driving at the airfield .....	37
1.8.9	flying Clubs at ENJB .....	37
1.8.10	Runway markings.....	39
1.8.11	Emergency response chart.....	40
1.10.0	Attachments to operational manual.....	43
1.10.1	Clubs / companies holding an agreement for the use of Jarlsberg.....	43
1.10.2	Emergency response team .....	43
1.10.3	Address and telephone numbers .....	44
1.10.4	Pricelist Jarlsberg Luftsportssenter .....	45
1.10.6	User declaration and legal disclaimer .....	46

# Part 1

## Operational policies and procedures

### 1.0.1 General Rules

These rules apply to all users, visitors and guests at Jarlsberg Jarlsberg Airfield.

Jarlsberg Jarlsberg Airfield has status as a "Privat Airfield."

This means that the airfield can only be used by persons who is approved by Jarlsberg Airsports Center.

There are no public services such as Airfield security, emergency service, Security control, ATC etc. In other words, all Airfield users reside and use the airfield at their own risk.

JARLSBERG AIRSPORTS CENTER has no direct duty to provide information to users, beyond the information provided in the Operating Guide and the meetings of the board members / observers and other officers.

It is each club's representative / observer in the Coordination Committee to inform his club and club members.

Smoking and open flames are prohibited in hangars and aircraft, vehicles, tank farms etc.

With the complex activity at Jarlsberg it goes without saying that there must be rules for its use, so that safety can be maintained in a proper manner. It is hopefully, equally clear that these safety rules must be followed by all and that the violation of the rules, can or will not be accepted.

As long as Jarlsberg Airsports Center is the operator responsible for Jarlsberg, it will be emphasized that all activities are legal and in accordance with adopted rules and regulations. It will be conducted frequent inspections of all conditions, and orders of the inspectors shall be complied with immediately and without discussion. If you do not agree with the examiner's decision, an appeal should be sent in writing to the Administration of Jarlsberg Airsports Center, which will treat the dispute as soon as the complaint is received.

Groups or individuals who refuse to comply with orders, and / or repeatedly break the rules for the use of Jarlsberg will be denied use of the airfield, and if necessary reported to the police.

Children under 10 years must be accompanied by an adult and there must be taken great care with regards to planes, parachutists, etc. To avoid any hazard. Children should always be supervised by adults.

Dogs and other pets are welcome Tønsberg Airfield Jarlsberg. It is the owner's responsibility to ensure that these are kept on a leash and kept away from places where dangerous situations can occur.

Airfield manager may grant an exemption from this requirement in certain areas and on certain conditions.

Visitors are welcome to look at airplanes and other materials, Visitors that wants access to the manouvering area has to be escorted by a registred member of one of the operating clubs at the airfield. High visibility vest shall be used during stay on the manouvering area.

Visitors on Jarlsberg must respect all signs and follow any instructions from Airfield manager and other representatives.

Welcome to Jarlsberg.

## Conditions for use of Tønsberg Airfield Jarlsberg

### 1.1.1 Who can use Tønsberg Airfield Jarlsberg

Anyone who is registered as a user, or have a valid PPR, will be accepted at Tønsberg Airfield Jarlsberg according to the rules at any time.

No person may use Jarlsberg without prior agreement with Jarlsberg Airsports Center, ie possess a valid use registration as well as have acknowledged that the rules for the use of Jarlsberg is understood, accepted and will be followed. This means among other things that one has committed to pay landing fees, registration fees, etc. at the right time, in accordance with the then applicable rules and rates.

Operating assumptions set out in this document are part of the licensing requirements of the CAA.

Guests and visitors are not allowed to stay on the aircraft parking area in front of the hangars without being accompanied by a registered member of JLS. All registered users at Jarlsberg must wear high-visibility clothing when on the parking area in front of hangars and other locations where aircraft are being maneuvered.

### 1.1.2 Access and permission for use of the premises

1. No person has the unconditional right of entry, residence and use of ENJB. This applies to anyone, whether that person is an employee representative, member of Jarlsberg Airfield Club, lessee, owner / co-owner of the aircraft, guest, casual visitors or whatever.
2. Person who is rejected or expelled are not entitled any explanations from JLS.
3. Airfield manager (FLSJ) and JLS Board exercises full authority over all personnel throughout ENJB outdoor and indoor as specified in these regulations. Any given permission is always conditional on the person's behavior. Access key and signed operational manual gives no privilege in this context.

For full and complete explanation see Norwegian version, Part 2 Section 2.7.0

### 1.1.3 Security. Prevention of security threats

The Norwegian Civil Aviation Authority has granted Jarlsberg Luftsportssenter permission to establish designated areas (Designated Area) to meet the requirements of the Security regulations §3.

The airport is obliged to ensure that the alternative security measures are taken into account.

The following measures replace the measures that apply to large airports with regular passenger traffic.

- Only persons and vehicles with legitimate reason may be in the designated area (DA). Persons and vehicles must be able to present authorization in the form of a JLS ID card or membership card in one of the clubs based in Jarlsberg, and possibly a driving permit issued by JLS.
- All registered members/users of Jarlsberg are obliged to be aware of persons and vehicles staying in a DA area without legitimate reason, and to expel them in accordance with procedures in the operations manual
- Procedures for the security program are not public and are therefore not reproduced in their entirety in this operations manual.
- Procedures for expelling persons can be found in the Operations Manual, Part 1, Section 1.1.1 and with additional information in Part 2, Section 2.7.0

- Aircraft must be protected against sabotage, theft and other threats to security. The aircraft must be checked for signs of sabotage, vandalism, and objects that may endanger security.
- On the aircraft stand with parked aircraft and at refueling facilities, signs of activity that may endanger security must be looked for.
- The airport manager is at all times responsible for the Security program at Tønsberg Airport Jarlsberg. The responsible person can be notified by phone at +47 940 08 400
- The DA area is indicated on the map in this operations manual, Section 1.8.10 and by notices in club rooms and on access roads to DA areas.

#### **1.1.4 Landing Fees.**

Visiting aircraft and private aircraft stationed at Jarlsberg should pay landing fees to Jarlsberg Airsports Center as specified in the price list in this document.

#### **1.1.5 Airshow / Events.**

No clubs, organizations, businesses or individuals with or without base at Jarlsberg, can hold any kind of events, conferences or airshow, without prior written agreement / permit is issued by the administration of Jarlsberg Airsports Center.

The permit shall state what is to be paid in conference fee and any other conditions that f. Items. extended hours, which is the basis for the permit. Agreed conference fee shall be paid to Jarlsberg Airsports Center of competition organizer no later than 7 days after the conference is held.

#### **1.1.6 Definition of airshow**

A airshow is pr. definition an event where spectators are invited, its advertised or planned special organized activities.

#### **1.1.7 Payment of fees etc.**

Rental fees, Competition fees, landing fees etc is to be paid within the stipulated payment deadlines. If payment is not made after the reminder is made, this will cause a club, company or person will be denied further use of the premissis for the time period the administration of Jarlsberg Airsports Center decides.

#### **1.1.8 Exclusion**

People who repeatedly break the rules in this operating manual, or which by its activity could give Jarlsberg a bad reputation, will have their user registration revoked by the administration of Jarlsberg Airsports Center. Examples of activities that would be subject to such an assessment would be unlawful flight, repeated violations of the rules for use of Jarlsberg etc. Exclusion occurs after voting that provides a simple majority in Jarlsberg Airsports Center Board.

#### **1.1.9 Insurance**

Individuals, clubs or organizations that use Jarlsberg Airfield to an activity without a valid user registration must be aware that the insurance company may require recourse in the event of damage. The insurance coverage only applies to legally use, ie only to people with valid use registration

### **1.1.10 How to register as a user**

Anyone who wishes to use ENJB to an activity, ie is registered as a user, must send signed statement that the operating manual is read and accepted Jarlsberg Airsports Center. Form could be found at the end of the Operations Manual, Section 10.6.

Payment of user fee can be done in the following ways:

According to. invoice issued by Jarlsberg Airsports Center

All bank payments made to: JLS AS  
Flyplassveien 6  
3170 Sem.  
Bankaccount no. 2563.55.15581  
Remember to describe the payment!

### 1.1.11 Airfield Information

Name:	Tønsberg Airfield, Jarlsberg
International Airfield code:	ENJB
Location:	N591753 E102212 (About 4 km from Tønsberg) within the Torp control zone (118.655 MHz)
Owner:	Thor Solberg Aviation as
Status:	Privat Airfield
Radio Frequency ENJB:	135.215 MHz
Landing Pattern:	Standard
Maximum Elevation:	60ft
Runways:	18/36
Length (TORA / LDA)	799 m
Width:	18 m
Security Area:	9 m firm grass and further 7 m on farmland.
Surface:	Asphalt
Weight limit:	up to 5700 kg
Lighting:	No
Operator:	Jarlsberg Airsports Center
Airfield manager:	attached address list
Landing Fee in accordance:	Appendix 'Pricelist Jarlsberg Airsports Center'
No aircraft repair	
Fuel:	AVGAS 100LL /Mogas 95UL/ Jet A1, in agreement with TøFSK.
Other Services:	No

#### Other Information:

Operations at ENJB should only take place during daytime between sunrise and sunset, Restricted area southwest of the runway (model Airfield).

At times intense activity, from airplanes, gliders, model flying, skydiving and light sport aircrafts. Flying over Sem Church and buildings on east side of the airfield to be reduced to a minimum. All users must be registered in the user registration system established at Jarlsberg.

**Caution!** Cyclists, pedestrians and farming equipment do occasionally cross the runway. Check runway and safety area while on short final.

All operational personnel shall wear high visibility clothing at the maneuvering area

#### Arrival / departure procedures:

All planes that are "inbound" for Jarlsberg to contact Torp TWR at 118.655 before entering ENTO control zone for clearance to change to Jarlsberg frequency 135.215. Intentions and landing pattern is to be reported blindly at 135.215.

Planes taking off from Jarlsberg to contact ENTO by phone 33 42 61 52 T / O clearance.

T / O is to be reported then blindly Jarlsberg frequency 135.215.

After T / O report position and frequency switching back to Torp frequency 118.655.

### **1.1.12 Airspace**

Tønsberg airfield Jarlsberg is located in class D airspace, within Torp control zone (CTR)

Clarence to enter control zone shall be obtained from Torp tower. This is applicable to arrivals to, and departures from, Jarlsberg. All visiting aircrafts not permanently based at Jarlsberg have to obtain PPR from the internet based system found on "myppr.no". This permission is personal for the pilot in command.

### **1.2.0 Parking**

All visitors and operators of vehicles without vehicle permit are to park in the parking lots outside the entrance to the Airfield. Parking at the airfield inside the gate is not permitted for other purpose than loading and unloading.

No parking is to be done along the runway, taxiway and other areas that could be of hindrance to aircraft movements.

#### **1.2.1 Motor vehicles**

Only persons with a valid vehicle permit to operate a motor vehicle inside the Airfield area, these must comply with the applicable rules.

Parking should not be made along the runway, taxiways, or other places where parking can cause problems for air traffic on the airfield. Driving on grassy areas is only allowed unless directed by Airfield manager. Damage caused to aircraft, cars or other vehicles because of illegal parking, will entirely be the fault parked car driver's responsibility.

Violation of these rules will lead to the access card will be deactivated and the permit revoked.

Drivers are advised that the illegal driving on the Airfield, will void the vehicle insurance.

Note: The speed limit for motor vehicles on the Airfield area is 30 km / h.

#### **1.2.2 Parking and operation of aircraft on the ground**

Operation and parking of aircrafts at Jarlsberg requires that the pilot in command takes particular care that there is limited maneuvering and parking area available.

This requires great vigilance and care when maneuvering the aircraft on the ground, so that one does not cause damage to other aircraft, or park so that they are prevented from maneuver safely. Engine start and test should never be made so that the slip stream from the propeller hit other aircrafts, vehicles or buildings. Engine tests and runup shall be performed at the intersection taxiway "A" and "A1". This goes for any test of engines.

Pilots observed maneuvering so there is a risk that damage may occur, or park in such a way that the other aircraft is prevented to maneuver in a safe and prudent manner, must expect to be banned from flying at Tønsberg Airfield Jarlsberg for a period of time.

Compliance with the rules is the individual pilot's responsibility, but the club's management has a responsibility and must, if necessary provide guidance and advice to the pilots who may need this. Pilots maneuvering so that other aircrafts are damaged, have to replace the damage and in cases where they do not agree on the settlement, they will be refused the continued use of the airfield, until the matter is finally settled.

### 1.3.0 Rules for use of Jarlsberg

#### 1.3.1 Additional Rules for operating light aircraft and Light sport aircraft

1. Flight with light aircraft and Light sport aircraft at Jarlsberg is permitted only for persons with a valid use registration or valid PPR and day passes. Using Registration is each pilot's responsibility.
2. Flying club / Light sport aircraft club (s) are responsible for all members operating the club materials on ENJB registered. Members without valid registration must not be allowed to use the club's equipment. Violation of this rule will result in fines of the club, and by repetition, revocation of its license to operate in ENJB for shorter or longer periods.
3. Visiting pilots can only use Jarlsberg after Prior Permission is obtained.
4. Flying at ENJB should only take place according to the visual flight rules applicable to the aircraft and airspace.. After snowfall it is not allowed to use the runway if the snow depth exceeds 3 cm
5. On Saturdays, "Touch & Go" is only to be performed before 18:00 and on Sundays. and holidays "Touch & Go" can only be performed between at. 13:00 and 18:00. When there are gliding and parachuting activities, the T & Gs is due to coordination from respectively ASL or HL. Smoking near airplanes is strictly prohibited.
6. Maximum altitude in the landingpattern east and west is 1000 ft AMSL ore according to instructions from Torp TWR. Flying outside the landingpattern west of the field is not permitted.
7. During activities as, worship, wedding, funeral, etc. at Sem church, flying should be avoided. If this is not possible, it shall under no circumstances be flown on the east side of the airfield.
8. When Torp is open, the Pilot incommand shall establish contact with ENTO by phone 33 42 61 52 for clearance to enter controlled airspace before start up.
9. Torp TWR may be contacted on frequency 118.655 to submit the request as stated above, but this applies only in cases where it is not possible to use the phone. If given clearance can not be completed within 10 minutes, a new clearance sought.
10. Flying in the landing pattern and in the local area should be planned and conducted so that it would be to the least possible inconvenience to neighbors and the rest of the population. Direct overflight of residential areas on takeoff and landing is to be avoided, as far as safely possible.
11. Flights shall not take place below 1500 feet within the model area in the SW end of the field. Violation of this rule will result in penalties. The minimum altitude for crossing the runway and 500 meters runway extension is 1000 feet.
12. All traffic arriving Jarlsberg will enter the landing pattern for optional right or left downwind/base leg for the current runway in use and fly a landing pattern at standard height 1000 ft AMSL. Traffic arriving at 1500 ft AMSL shall descend to 1000 ft landing pattern altitude when entering the landing pattern. Local radio frequency 0 MHz is to be used at time operation on ENJB. Entering the circuit and all the swings and final, shall be reported solely on local frequency Unless otherwise specifically will be announced on local frequency, the

same runway in use as Sandefjord Airfield Torp, published på Torp ATIS 119.07. See map section. 1.8.1

13. Limitations to the landing pattern at Jarlsberg
14. The following additional provisions apply to downwind on the west side of ENJB:  
Downwind, shall be primarily used for training circuits.  
Downwind west should be flown on an imaginary line between the intersection E18 / Route 35 and the quarry.  
Aulielva defines the western boundary (north of the intersection E18 / Route 35), and should not be crossed to the west without clearance from Torp TWR.  
Holding on downwind west should not take place west of the border in the preceding paragraph.
15. Procedure for radio communication failure (RCF)
  1. If possible, the pilot in command who experiences radio faults during flight, contact Torp TWR on telephone 33426152 before Torp CTR enters - to inform about radio faults, as well as obtain clearance to enter CTR inbound to ENJB.
  2. Transponder to 7600.
  3. If it is not possible to obtain clearance from Torp TWR to enter Torp CTR, the pilot in command shall fly into CTR towards Jarlsberg directly from the east entering the landing pattern. The pilot shall visually check the area for traffic, and then land when the traffic situation indicates that this can be carried out in a safe manner.
  4. After landing, the PIC shall immediately contact Torp TWR on telephone 33426152 to report on the status.
  5. Departures from ENJB without a operating radio will not be permitted, but dispensation can be considered in special cases. Clearance to leave Torp CTR must be obtained from Torp TWR on telephone 33426152 before the flight is to take place.
15. Flights which operate in landing pattern at ENJB must keep themselves updated about the other traffic as well as skydiving, by monitoring ENJB frequency 135.215. When flying in the circuit or in neighboring areas possision and intention must be transmitted blindly Jarlsberg frequency 135.215. All turns in landing pattern reported blindly. Radio frequency 135.30 shall not be used for other communication than is pure flight safety required. Use of the transponder is mandatory for operations on and from ENJB.

**16.- Landing pattern - entry and exit**

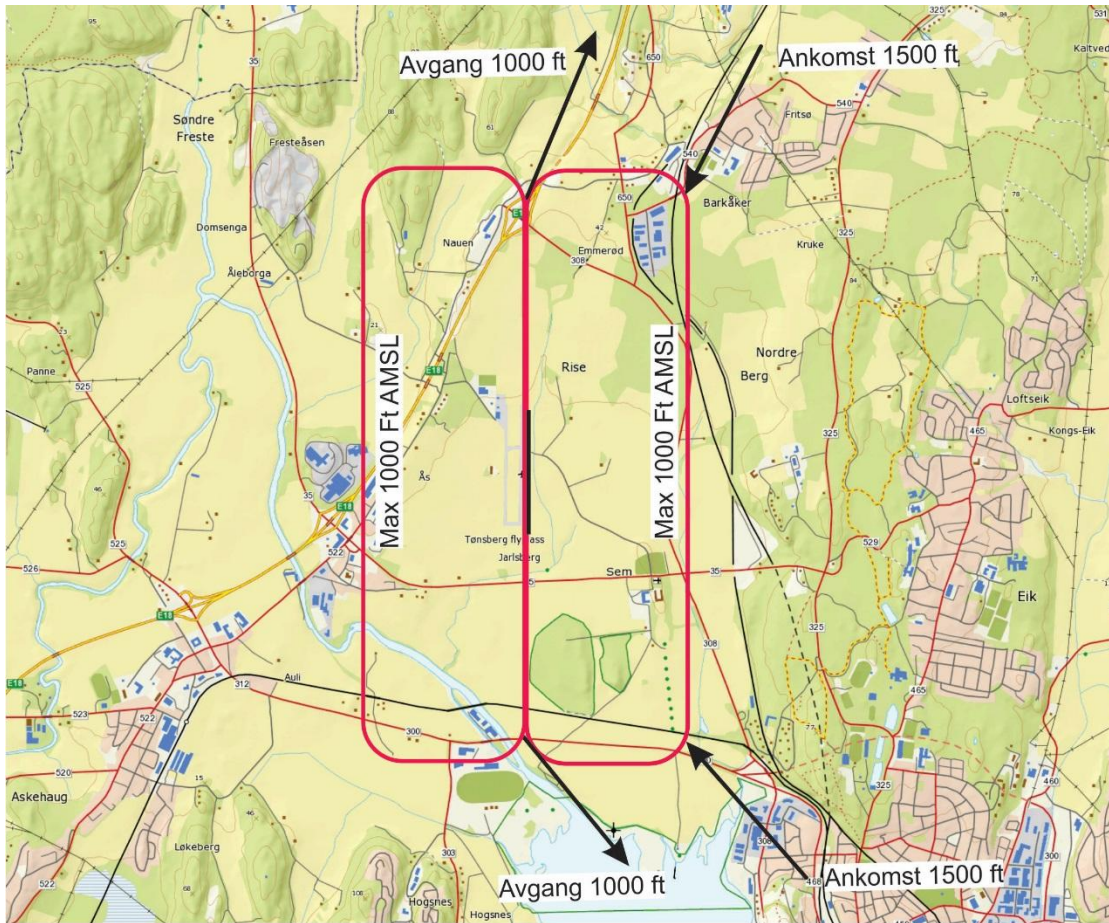

Standard arrival and departure routes at Tønsberg airfield Jarlsberg Landing pattern and TG should be alternated East and West of the runway.

### 1.3.2 Additional rules for gliders

1. Flight with gliders at Jarlsberg can be made by persons with a valid use registration. Registration is each pilot's responsibility.
2. TSFK is responsible for ensuring that all members operate its material on Jarlsberg has a valid user registration. Members without valid registration shall not be permitted to use the club's equipment on ENJB.
3. visiting glider pilots can only use Jarlsberg after the registration is completed, the user grants paid.
4. Before gliding operations are started, ASL shall be appointed according to NLF/S rules, ground radio station established, permission from the air traffic controller obtained, and sufficient crew to operate safely in accordance with the valid regulations. Smoking near the tow plane/glider is strictly prohibited.
5. If skydiving is in operation ASL / Ground Manager shall contact HL and agree on the operational conditions of today's flight.
6. Gliders / tow plane shall not be parked so close to the runway / taxiway that it represent problems for other aircraft.
7. Glider Trailers and cars must be parked in such a distance from the taxiway routes that they do not hinder other traffic, or creates difficult operating conditions for other users. Damage caused to planes due to wrong parking charged to the owner of the parked vehicle.
8. On holidays glider operations will be started after 12.00 and be finished by sunset.
9. Flying gliders and tow plane at ENJB should only take place during the day between sunrise and sunset.
10. On Saturdays, flying is only to be performed before 18:00 and on Sundays. and holidays flying can only be performed between at. 13:00 and 18:00.
11. Tow pilots should vary their routes during the day, in order to distribute the noise as much as possible. Route Variation shall take presedence to best route for thermals etc. Glider towing shall as far as it is safely possible be performed outside residential areas.
12. The tow line should be removed from the runway as soon as possible after the line drop. Ground personnel should as far as possible stay out of safety zone when aircraft are coming in for a landing.
13. Flights shall not take place below 1500 feet within the model area in the SW end of the square. Minimum height for crossing the runway and 500 meters runway extension, is 1,000 feet.
14. All traffic arriving Jarlsberg will enter the landing pattern for optional right or left downwind for the current directory to use and fly a complete airfield in standard height 1000 ft AMSL. Local radio frequency 35.215 MHz is to be used at time operation on ENJB. Entering the circuit and

all the swings and final, shall be reported solely on local frequency Unless otherwise specifically will be announced on local frequency, the same court direction Sandefjord Airfield Torp, published påTorp ATIS 119.07. See map section. 1.8.2

15. All gliders operated from Jarlsberg must have transponder. When glider operations are terminated, air traffic controller shall be notified. The Use of radio follows the same rules as light aircraft.
16. Procedure for radio communication failure (RCF)
  1. If possible, the pilot in command who experiences radio faults during flight, contact Torp TWR on telephone 33426152 before Torp CTR enters - to inform about radio faults, as well as obtain clearance to enter CTR inbound to ENJB.
  2. Transponder to 7600.
  3. If it is not possible to obtain clearance from Torp TWR to enter Torp CTR, the pilot in command shall fly into CTR towards Jarlsberg directly from the east entering the landing pattern. The pilot shall visually check the area for traffic, and then land when the traffic situation indicates that this can be carried out in a safe manner.
  4. After landing, the commander shall immediately contact Torp TWR on telephone 33426152 to report on the status.
  5. Departures from ENJB without a operating radio will not be permitted, but dispensation can be considered in special cases. Clearance to leave Torp CTR must be obtained from Torp TWR on telephone 33426152 before the flight is to take place.
17. For operations with the motorized gliders and glider tug regulations for flying with light aircraft and Light sport aircraft in section 1.3.1 above applies.
18. Gliding, which involves the use of tow plane shall normally be carried out on the east side of ENJB. Request to fly gliders in Torp CTR between 1500 and 2500 FT will normally be granted if the traffic situation allows it.
19. Prior to departure, the towing aircraft shall obtain clearance for that flight as with light aircraft and Light sport aircraft described above.
20. When allocating transponder code to both tow plane and gliders, sailplanes shall set transponder to "Standby" until this is disconnected from the tow plane.
21. After disconnection has taken place, tow plane and gliders is perceived as two separate flights and glider will immediately establish radio contact with Torp TWR on frequency 118.65.
22. Tow plane and gliders will individually obtain separate clearances in accordance with clause 4.2 above before flying inbound to ENJB can take place.
23. The above follows an agreement between JLS, Sandefjord Airfield Torp and Avinor. See "Scheduling verdor aktiviteter by ENJB in Part 1, Appendix 1
24. If any of these provisions would conflict with the instructions / rules issued by the Authority, the Civil Aviation Authority rules and regulations apply.

**1.3.3 Additional Rules for helicopter flight**

**Helicopter operations at ENJB is prohibited without prior written permission from Jarlsberg Airsports Center. Police, air ambulance, armed forces and rescue services is except this provision.**

#### 1.3.4 Additional Rules for skydiving

1. Skydiving on Jarlsberg is permitted only for skydivers with valid registration in the user registration system. All operations at ENJB shall take place in accordance with the "Agreement on activities at ENJB" between Sandefjord Airport, Avinor Torp tower and JLS as. As well as the parachute club's own agreement with LTT Torp and LTT Farris.
2. TøFSK is responsible for ensuring that all who use JLS for skydiving are registered. No one should be allowed to jump without a valid registration in the user registration system.
3. Before skydiving commences it shall be appointed a drop zone Lead (HFL), and obtained clearance from air traffic control and have provided information to other users of the airfield. HFL must have radio contact with the airplane and report when all jumpers in a lift is on the ground, as well as transmitting blindly any deviations in landing pattern and possible conflicts with other aircraft in the landing pattern
4. All activities shall be in accordance with the operating rules and regulations governing the skydiving activity.
5. Skydiving at ENJB should only take place during the day between sunrise and sunset. skydiving shall not start before 13.00 on holidays, and jumping shall be ended, and parachute plane landed no later than 18.00 hrs on Saturdays and holidays.
6. Minimum altitude for crossing the runway and 500 meters of the runway extension line, is 1000 feet. If wind conditions make this impossible, the skydiving activity is to be terminated.
7. The same rules apply to parachute plane as to flight with other light aircrafts and ultralight. All traffic arriving Jarlsberg will enter the landing pattern for an optional right or left downwind or minimum at base, for the current runway in use. See map section. 1.8.2 Local radio frequency is to be used at all time operation on ENJB. Entering the circuit and all the turns and the final shall be reported on local frequency. Unless otherwise specifically announced on local frequency, runway in use is the same as Sandefjord Airfield Torp, published at Torp ATIS 119.07.
8. Before departure, the parachute aircraft has to obtain clearance as for flights with light aircraft and Light sport aircraft as described above. parachute aircraft is governed by the same rules as for any other flights at jarlsberg except for the following. The first contact made to Torp is to be done by telephone. Subsequent contacts in a series of flights could be done using Torp Tower frequency 118,655.
9. Torp TWR will coordinate route and altitude with Farris approach on request. The parachute plane shall remain and monitor Jarlsberg frequency unless ATC say otherwise. Paradrop and drop location shall always be transmitted on Jarlsberg frequency.

Those procedures stated above is in conformity with the agreement made with JLS, Sandefjord lufthavn Torp and Avinor. For more information see: "Avtale verdørende aktiviteter ved ENJB i Del 1, vedlegg 1

10. Minimum altitude within model flying area in the south west corner of the field is 1500 feet. If wind conditions make this impossible parachuting activity must be stopped.
11. All Skydivers shall use the dedicated landing area.
12. Parachute aircraft shall vary there climb out route as much as possible. This in accordance to local club procedures and procedures agreed upon in cooperation with ATC Torp
13. Al pilots flying the skydiving airplane is to be registered in the user registration system and have paid their annual user fee. They shall follow the additional rules for flying skydivers at Jarlsberg. Smoking and use of bare flames in the vicinity of aircrafts are strictly prohibited.
14. If any of these provisions would conflict with the instructions / rules issued by the Authority, the Civil Aviation Authority rules and regulations apply.

#### **1.3.4.1 Checklist before parachuting**

##### Checklist before jump start

This checklist should be reviewed daily before jumping can begin. Signed checklist must be hung on the notice board in the manifesto.

No. OK

1. Is HL approved and documented?
2. Is HFL approved and documented?
3. Are all ground crews informed about the current planned activity?
4. Are fire and emergency equipment controlled and available?
5. Is the radio and HFL telephone controlled and satisfactory?
6. Are all vehicles equipped with the necessary radio and lighting equipment?
7. Is information to other actors at the airport considered?
8. Are there other activities that can be affected on the site?
9. Is the pilot on the jumper informed and approved by the airport manager?
10. Is aircraft bunkering equipment checked and in order?
11. Are tasks and responsibilities distributed and confirmed?

Date Signature

Jumping can start

Date Signature



### 1.3.5 Additional Rules for model and drone flying.

1. Flight with model aircraft, drones and model helicopters at Jarlsberg is permitted only for persons with a valid use registration. User Registration is each pilot's responsibility.
2. The modelflying klubb shall appoint a safety manager, who is responsible for the safe operation of any models and any activity in the modelflying area. The procedure for this could be found in part 2 point 2.6.3
3. If Torp TWR need to suspend activities with model aircraft, they will activate an alarm function (Strobelight + siren) by model airplane club.  
When the alarm function is generated, all activities with model aircraft or drones should be terminated as quickly as possible, and safety manager model (SLM) should then contact Torp TWR by phone 33 42 61 52 to clarify the following matters:
  - Report that all model flying has been terminated
  - Acquiring cause for the alarm, as well as the expected time of commencement of normal activities
  - report the mobile number that SLM can be reached when normal activities can be resumed
4. The above follows agreement between JLS, Sandefjord Airport Torp and Avinor. See "Agreement on activities at ENJB in Part 1, Appendix 1
5. Model flying club are responsible for all members operating the club materials on ENJB registered. Members without valid registration must not be allowed to use the club's equipment. Violation of this rule will result in fines of the club, and by repetition, revocation of its license to operate in ENJB for shorter or longer periods.
6. All flying with model airplanes or drones shall take place within the area in the SW end of the airport. Activities with model airplanes/drones shall only take place below 1000 FT AGL within area limited by the following coordinates:
7. 59° 17' 52,3N – 011° 22'. 06,4E
  - a. 59° 17' 28,7N – 010° 22'. 08,7E
  - b. 59° 17' 28,7N – 010° 21'. 45,5E
  - c. 59° 17' 52,3N – 010° 21'. 44,0E
  - d. (59° 17' 52,3N – 011° 22'.06,4E)
8. The board of JLS may give a written permit to deviate from this rule.
9. Model Flying with special models or drones, of the main runway, should follow a procedure as specified in clause: 1.11.0
10. All model/drone flights are required to be performed according to the rules for model planes. The rules for use of Jarlsberg will be read, understood, accepted and acknowledged by each pilot before flight begins. Forms for this are the end of the Operations Manual.
11. Pilots operating a model airplane, drone or model helicopter at Jarlsberg shall have liability insurance through NLF or other similar arrangement. Model Pilots without membership / insurance in NLF must be able to show proof of payment of insurance upon request.

12. On holidays model flight should not be started until 13.00, and on Saturdays and holidays all flights should be completed no later than 21:00.
13. When other activity is taking place simultaneously Model/drone flying shall be coordinated with the competent person responsible for the / any other activities that take place.
14. Driving a motor vehicle for model area requires a valid driving permit. At the airport, the speed limit for motor vehicles is 30 km / h.
15. Smoking around aircraft, model airplanes and flammable fuel is strictly prohibited.

If any of these provisions would conflict with the instructions given by the Authority, the Authority, rules and regulations apply.

## **11.4.0 Rules for club activities without a permanent base on Jarlsberg**

### **1.4.1 Members of clubs without permanent base at ENJB**

Members of clubs that is not based on ENJB can use the airfield after agreement with Jarlsberg air sport center. They cannot use ENJB for activities that are already established through the owner clubs at ENJB. Such activity must always be approved by the board of the club in question, and by the board of JLS as. It should be verified and signed for that the Operations Manual is read, understood and that the rules for use of Jarlsberg will be followed.

### **1.4.2 Other Activities**

The fact that Tønsberg Airfield Jarlsberg, is an Air Sports centre is not an obstacle for JLS to approve arrangement of ground activities such as test drives of cars, karting, equestrian and similar.

Anyone wishing to utilize the area must also be registered in the user registration system. Or possess a special permit from Jarlsberg Airsports Center. The operating permit from the CAA applies 'Airport to private use'. Jarlsberg Airsports Center must therefore as the responsible operator, with the authorities at all times have full control over who uses the airfield. It is important that all users confirms in writing that they have read, understand and follow the rules given in the Operations Manual for Jarlsberg.

## **1.5.0 Reporting**

### **1.5.1 Irregularities**

Irregularities in the operation on ENJB shall be reported as soon as possible to Airfield manager or his deputy. Ref. contingency plan for Jarlsberg Air Sports center.

### **1.5.2 Accidents**

Accidents must be reported as soon as possible to Airfield manager or his deputy. and to other interested parties, for example. ATC, CAA, insurance, NLF etc. Ref. Contingency plan for Jarlsberg Air Sports.

### **1.5.3 Accidents**

Accidents must also be reported to the Police, CAA, Insurers NLF, the Board of Jarlsberg Air Sport center AS and any other interested parties. Ref. "Contingency plan for Jarlsberg Air Sports".

If there are damage to aircraft, vehicles or persons, special reporting forms shall be filled out and sent to the relevant authorities and organizations in accordance with the rules and regulations that apply at any time for the different activities.

Failure to comply with reporting requirements could lead to operations at Jarlsberg will be denied for shorter or longer periods.

## **1.6.0 Contingency plan**

### **1.6.1 Introduction.**

The objective of the emergency plan for Jarlsberg will be to ensure that all necessary and mandatory measures that may be required in connection with an emergency or accident are safeguarded in the best possible way.

In purely practical terms this is addressed by the establishment of an emergency team with members from operators of fixed bases at Jarlsberg.

Overview of emergency team members are in a separate attachment to this document in section. 10.2 marked 'emergency team' and on bulletinboards in club house.

Fire and Rescue service at Jarlsberg Air Sports Centre is organized according to the requirements of operational handbook, taken into consideration that the airfield is unmanned.

Since the airport is unattended, with personnel present only sporadically, users themselves will be responsible for safety and notifying emergency services and the emergency response team.

First aid equipment, firefighting equipment, etc. are available in the heated shed in hangar 1, for all users of the space.

Otherwise, it is required that the clubs have their own emergency plans.

Accident Map: See section 8.12

#### 1.6.2 Notification of emergency / accident / incident

1. Tønsberg Fire Service notified by dialing 110.

The message to Tonsberg Fire Service shall include:

- The time of the event.
- Location Specification / position.
- Persons involved
- Brief description of events.

Police will be automatically notified of Tønsberg Fire Service, but will also need the following information:

- If the accident include aircraft or vehicle: Registration and type.
  - The aircraft / vehicle owner.
  - Pilot in Command / operator.
  - Number of persons on board.
  - Damage to 3. party property.
- Notify the nearest air traffic services Sandefjord Airport Torp on telephone no. 33 42 61 52.  
Or Torp TWR on frequency 118.65
- Notify crisis management at Jarlsberg Air Sports. Airfield manager on telephone 94 00 84 00
  - Establishing communication with crisis management.
  - Assist crisis management as needed.

### 3. At the accident site.

- Assist the injured personnel to emergency medical personnel arrive.
- Blocking of the area and keep unauthorized personnel away.
- Referencing the press to media spokesperson / crisis manager.
- Cooperate, if necessary, assist the police and rescuers.
- After the damaged equipment / injured people have been removed, secure the accident site, if necessary with security personel so that any evidence is secured.

### 4. Contingency Group responsibility.

- Preparedness group leader is to decide who should speak to the media in connection with the incident.

- Contingency group leader coordinates the work with the police and, if necessary. Public Crisis Team
- Contingency group leader delegate responsibility for reporting etc. to the operational unit that is affected by the incident. Reporting should be in accordance with the operating rules of the activity that is affected.
- Contingency group leader is responsible for the accident site is secured and if necessary, arrange for security guards.
- Contingency group leader will be responsible for calling in special safety teams if this seems necessary or someone asks for this.

It is important that the Crisis Manager and emergency group acting calm and restrained. Furthermore, the instructions in BSL E-4-4 shall be followed.

### 5. Aids.

The following emergency and fire protection equipment is placed in the shed in H1.

- 1 piece 12 kg powder extinguisher
- 2 x 6 kg CO2 håndslukkingsapparater.
- 2 pieces of blankets
- 2 crash axes
- 2 first aid kit
- 2 pairs of fire gloves
- 8 x 12 kg powder extinguisher for firefighting aircraft.
- 1 complete fire clothing (full suit, helmet, gloves and boots)
- 1 bolt cutter

- 1 first aid kit
- Hazmat kit for clean up of spill.

6. Emergency service.

**REMEMBER:**

Fire service and ambulance is to be notified first by an accident at Jarlsberg. Telephone No. 110/113. The fire department will automatically alert the police, but the ambulance must be ordered separately on telephone No. 113

7. Notification of event.

An incident is an undesirable situation that happened on ENJB and under adverse conditions could lead to an accident. Such incidents must be reported in writing to Jarlsberg Airsports Center. Before any report sent external authorities / organizations, all parties involved have had an opportunity to comment on the incident to Jarlsberg Airsports Center / Airfield manager.

#### **1.6.4 Responsibilities and duties of CEO of Jarlsberg Airsports Center**

The manager is the top administrative officer in Jarlsberg Air Sports center AS (JLS). Responsibilities, duties and conditions is determined by the Board.

The CEO reports to the board by its Chairman (or Deputy).

#### **1.6.5 Operational operating ENJB - airport manager (FSJ)**

CEO reports as specified and Airfield Manager reports (only) administratively to the CEO and technically / operational to Civil Aviation Authority (LT)

5.1. If the functions CEO and Airfield Manager held by the same person, concerned shall be given in every context be diligent with regard to highlight in what capacity you are acting.

5.2. If functions of CEO and Airfield Manager held by different people, the CEO assist Airfield Manager in all administrative matters and arrange for Airfield managers effective exercise of work related to the persons responsibilities, such as:

5.3. Prepare for visitors to ENJB and establish a control arrangement for visitors - be it by plane, car, other, including the levying of JLS fees for such.

5.4. Administer / update ENJB Operation Manual

5.5. Administer / update user control system

5.6. Administer / update security control system

5.7. Administer systems for fuel handling and safety

5.8. Maintenance: Manage and update plans and cost estimates.

#### **1.7.0 Abbreviations**

ASL Responsible Leader, Gliders. ASL is primarily responsible for glider operations.

BSL Civil Aviation Regulations

BS Responsible Leader for gliders activities on the ground.

ENJB Europe - Norway - Jarlsberg, International Designation Jarlsberg Airfield

F / NLF Parachute Section / Norwegian Air Sports Federation

HFL HFL is responsible for parachute activities on the ground.

HL Operationally responsible for skydiving.

JLS AS Jarlsberg Air Sport center AS, the operating company.

LT CAA. Authority for issuing certificates and airport concessions in Norway

NLF Norwegian Air Sports Federation / Norwegian Aero Club. Luftsportsinteressenes central organization in Norway.

JSK Jarlsberg Light sport aircraft club,

S / NLF Gliders Section / Norwegian Air Sports Federation

TFK Tønsberg FlyveKlubb. .

TMFK Tønsberg ModelFlying clubb.

TSEK Tønsberg Glider flying club.

TøFSK Tønsberg Parachuters club.

T & G Touch & Go. Landing and departure without any ground stop.

### **1.7.1 Definitions**

Club based at JLS

Club that uses JLS as headquarters for their activities and have an agreement of use with Jarlsberg Airsports Center. Normally such club also have their clubhouse on site.

Driving permit JLS

Card with owner's name, address and driving-permit number. Card entitles the holder to operate vehicles inside the Jarlsberg airport perimeters on the given conditions at any time.

JLS Jarlsberg Air Sports.

Jarlsberg Airsports Center Jarlsberg

The operating company is responsible for operation, maintenance and upgrading of Jarlsberg Air Sports.

## **1.8.0 Charts**

1.8.1 Approach charts ENJB / ENTO

1.8.2 Airfield chart

1.8.3 Jarlsberg modellfflying area

1.8.4 Model flying area on chart.

1.8.5 Landing area for parachuters

1.8.6 Aircraft parking.

1.8.7 Carpark

1.8.8 Driving at the airfield

1.8.9 Clubs location

1.8.10 Runway marking

1.8.11 Emergency response chart

### 1.8.1 VFR Approach chart ENJB / ENTO

For visual and VFR approaches and reporting points in Torp control zone see:

AIP AD

ENTO

VFR-ROUTES LIGHT AIRCRAFT AND HELICOPTERS

Landing pattern at ENJB.

Tønsberg Airfield Jarlsberg is a non towered airfield. To separate traffic in the landing pattern the landing pattern shall be entered at any point on downwind or base at 1000 ft AMSL on the east side of the runway. Straight in on final is not allowed.

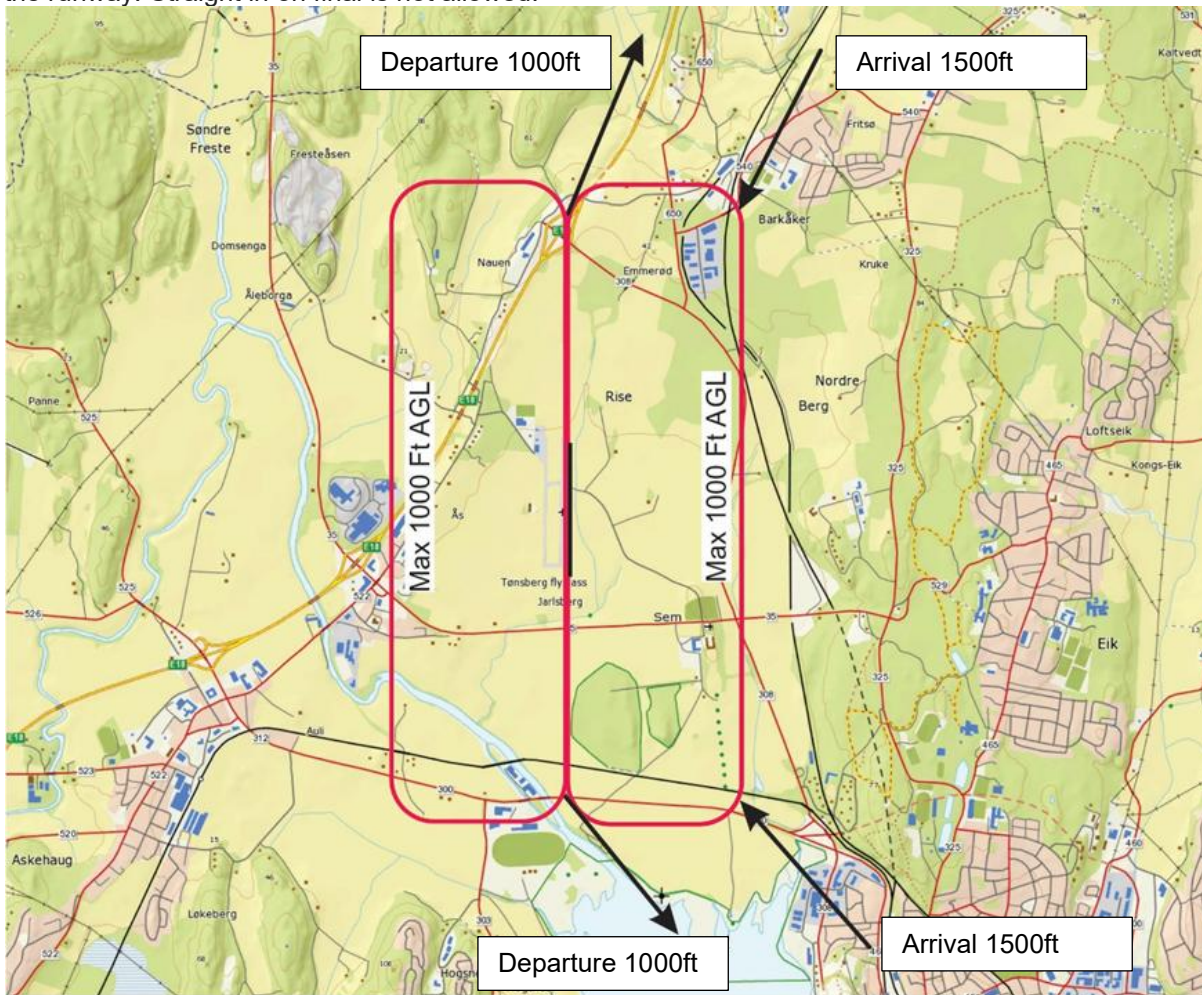

Standard arrival and departure routing at ENJB.  
 Parachute plane depart runway heading to 2500 ft. Before paradrop all planes in the pattern and arriving planes shall on request from Torp Twr, enter a holding outside of the CTR. At the clarens from Torp they could reenter the pattern at ENJB



## 1.8.2 Airfield chart

Runway and taxiway system at ENJB consist of:

Runway 18/36.

Taxiway «A» north/south

Taxiway «A1» East/West appr. midfield.

Exit og enter point (A2), and (A3) is not currently in use.

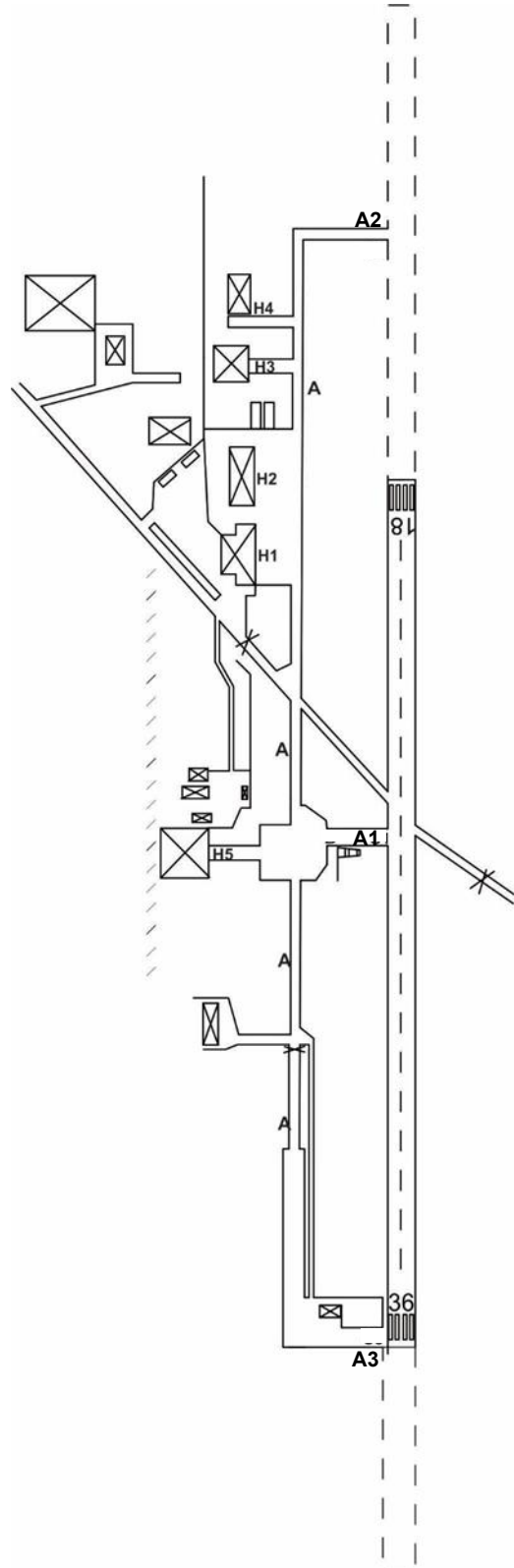

1.8.3 Jarlsberg modellflying area

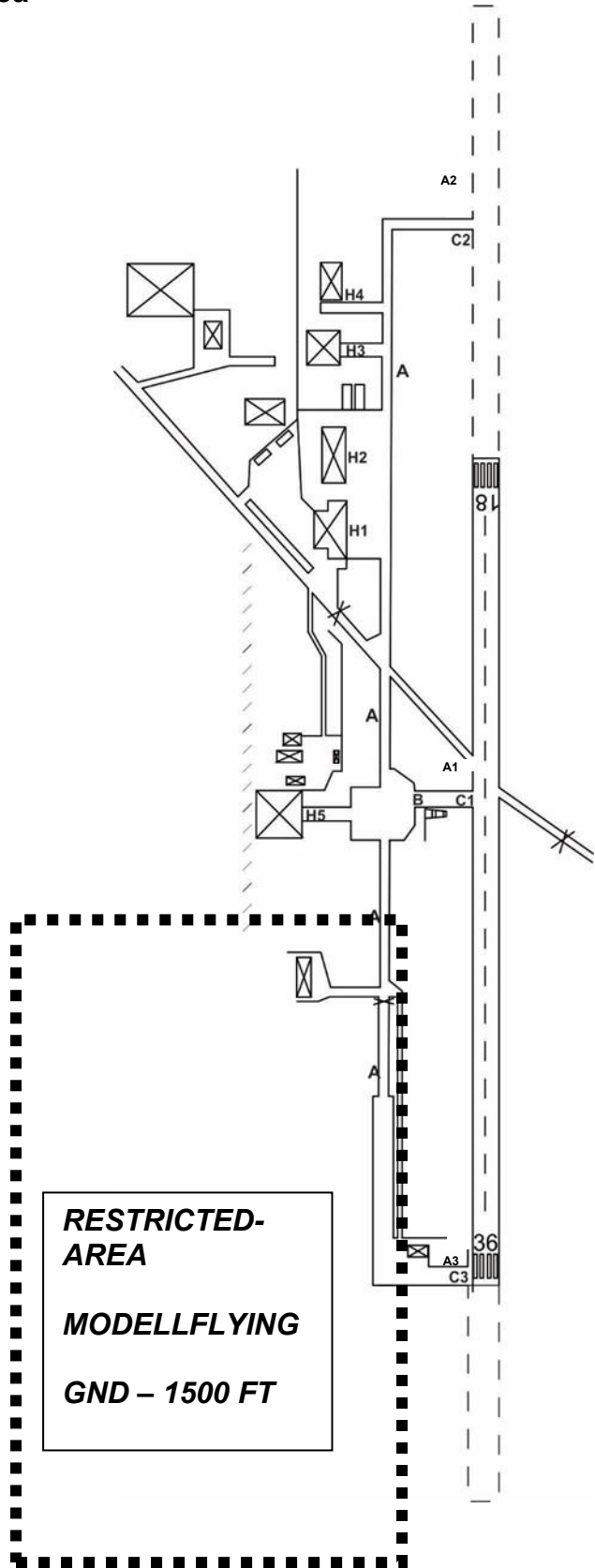

### 1.8.4 Model flying area



1.8.5

Landing area parachuters

A1

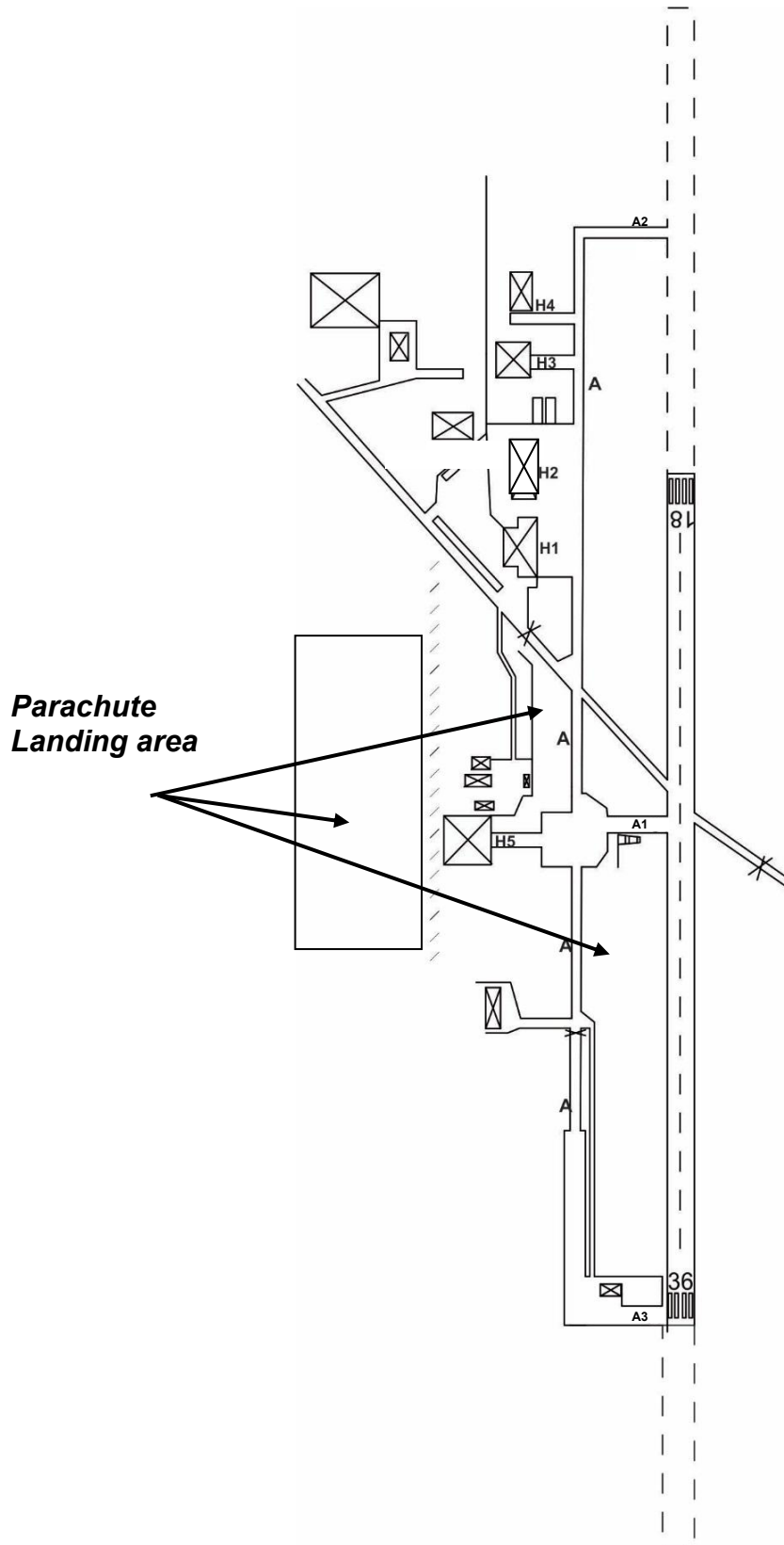

**1.8.6 Airplane parking**

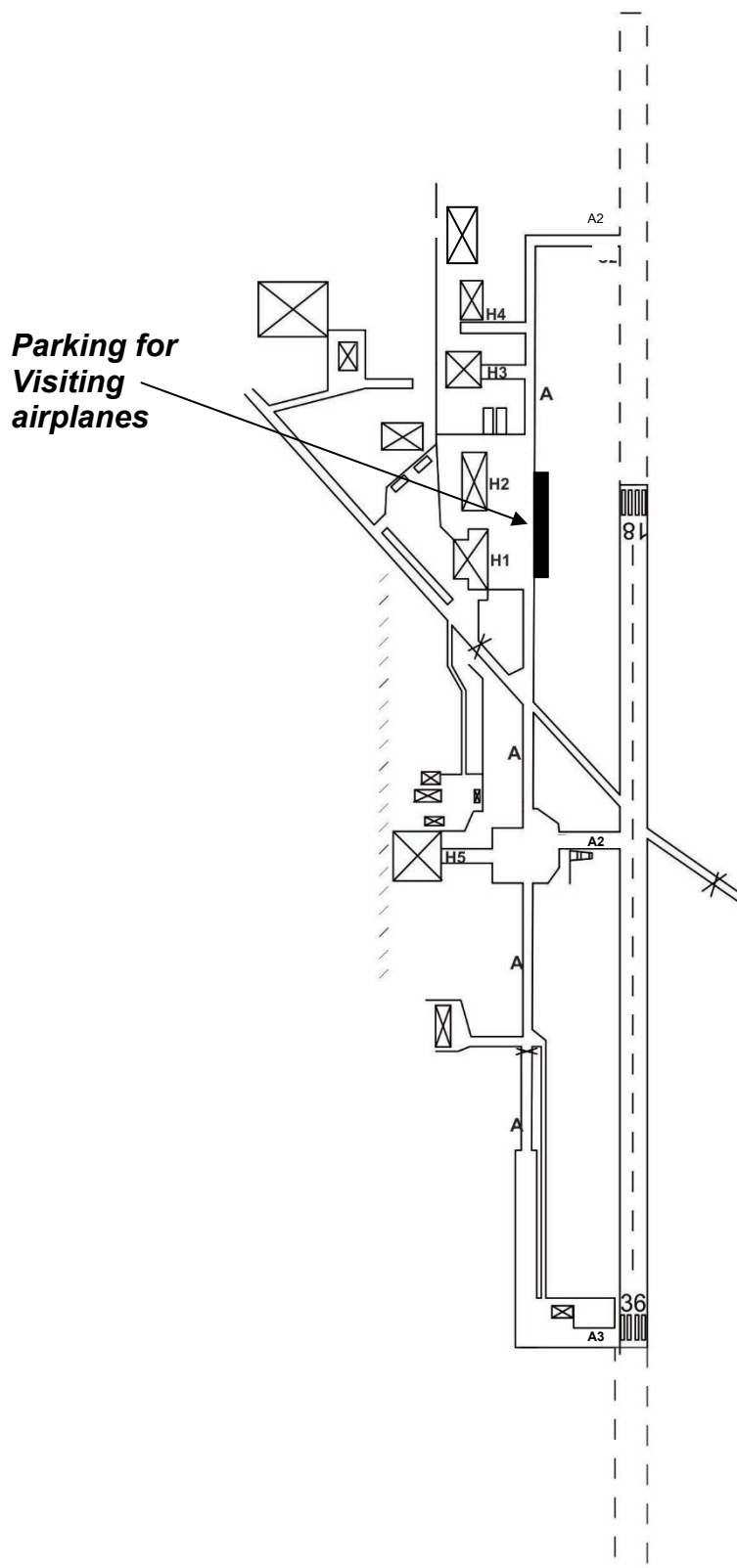

**1.8.7 Car Park**

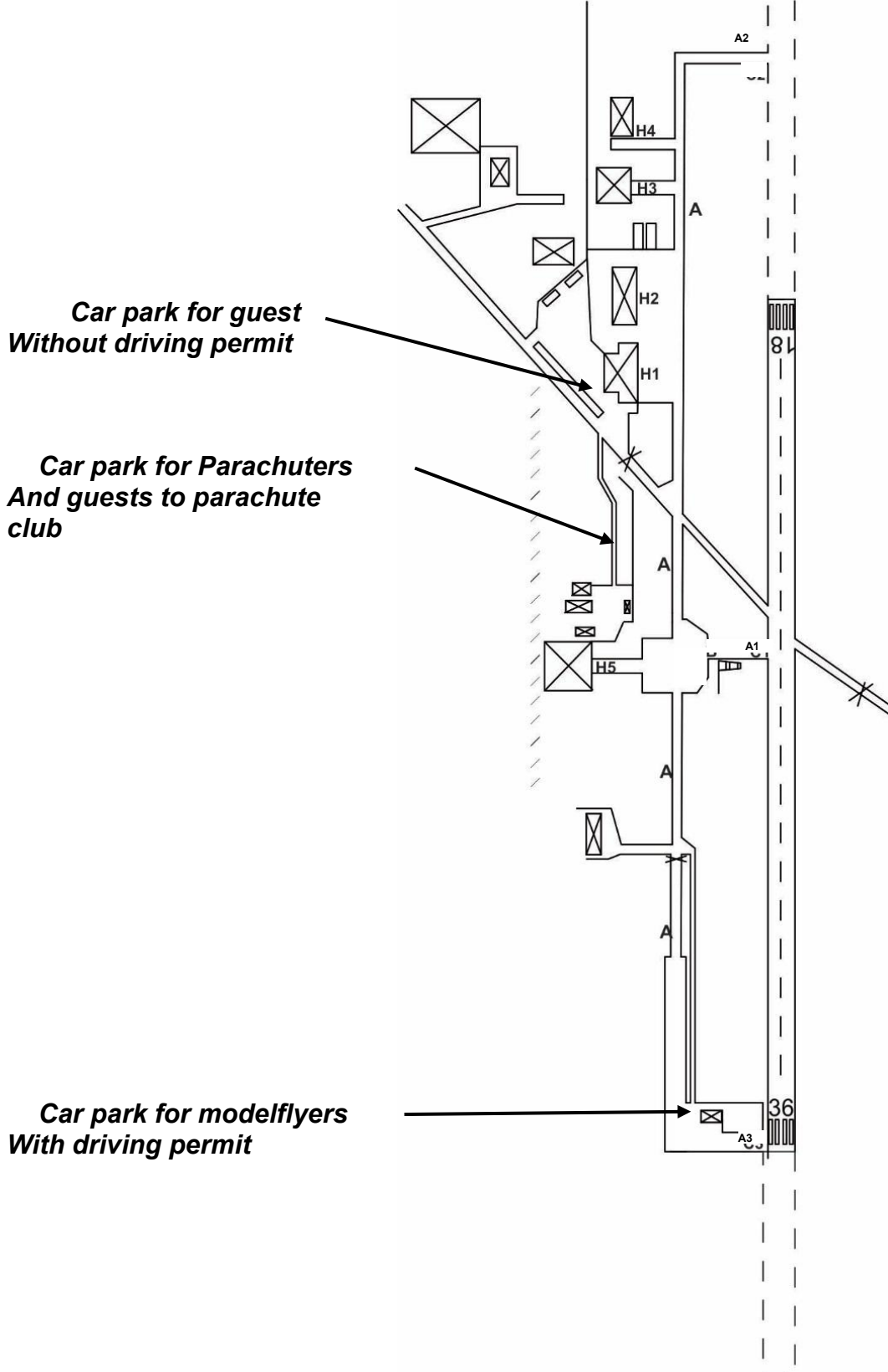

1.8.8 Driving at the airfield

**Autorised use of vehicle  
inside the gate.  
Operator must have driving permit**

**Max 30km/t inside the airfield  
perimeters**

**Driving a vehicle on the runway is not  
allowed without a written permission,  
Mandatory two way radiocom  
Blind transmision as all aircrafts**

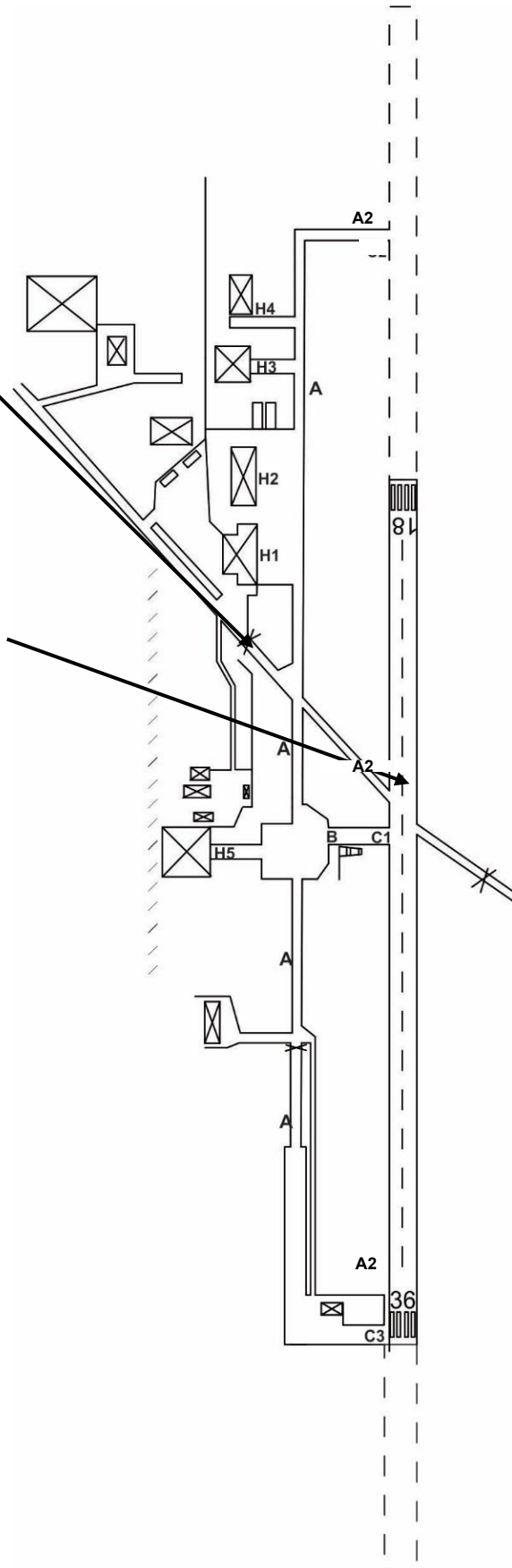

1.8.9 flying Clubs at ENJB

# Fire and Rescue First aid equipment

Jarlsberg Sportsflyklubb

WON

Jarlsberg Sportsflyklubb

Tønsberg Flyveklubb

Tønsberg Seilfly Klubb

Jarlsberg Sportsflyklubb

Jarlsberg Luftsportssenter AS

Infotavle

Tønsberg Fallskjerm Klubb

TSA bygg

Tønsberg Modellfly Klubb

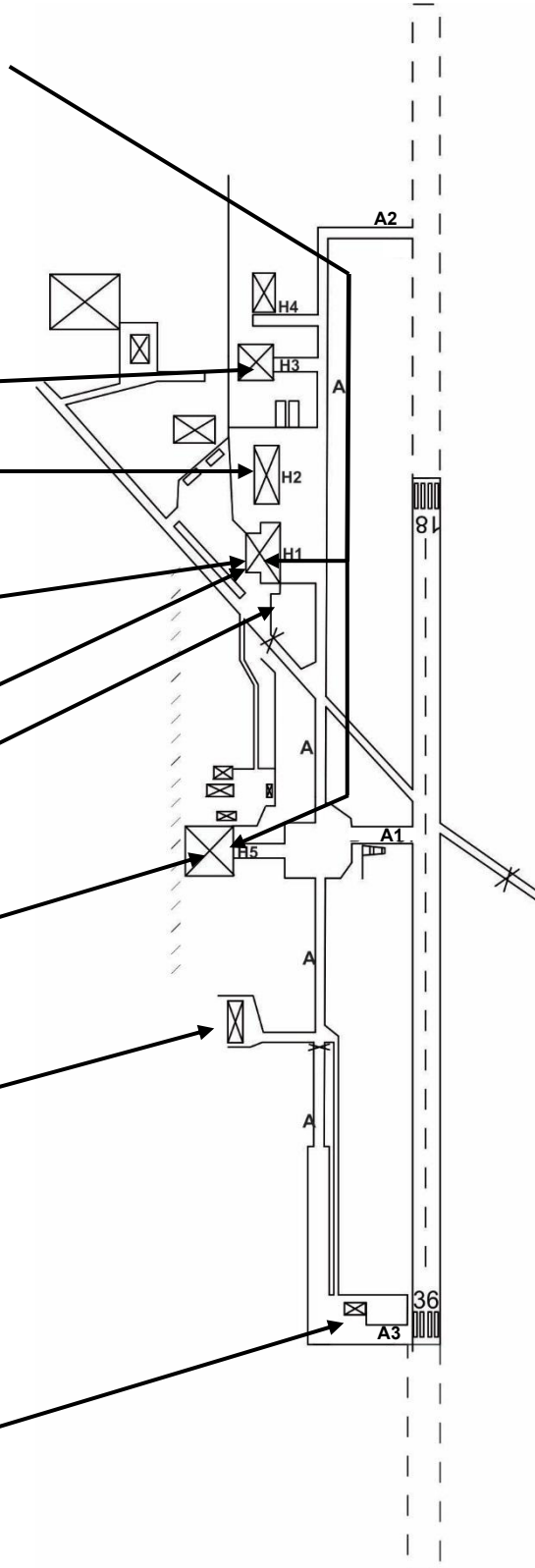

### 1.8.10 Runway markings

The runway is marked in acc with BSL-E 3-3  
(Not to scale)

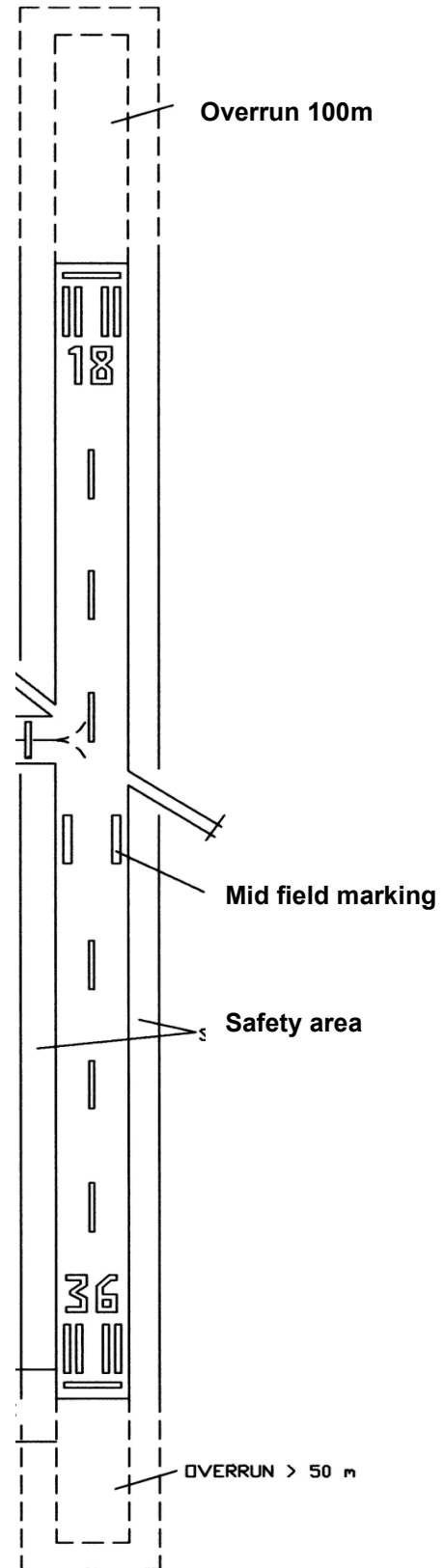

1.8.11 Emergency response chart

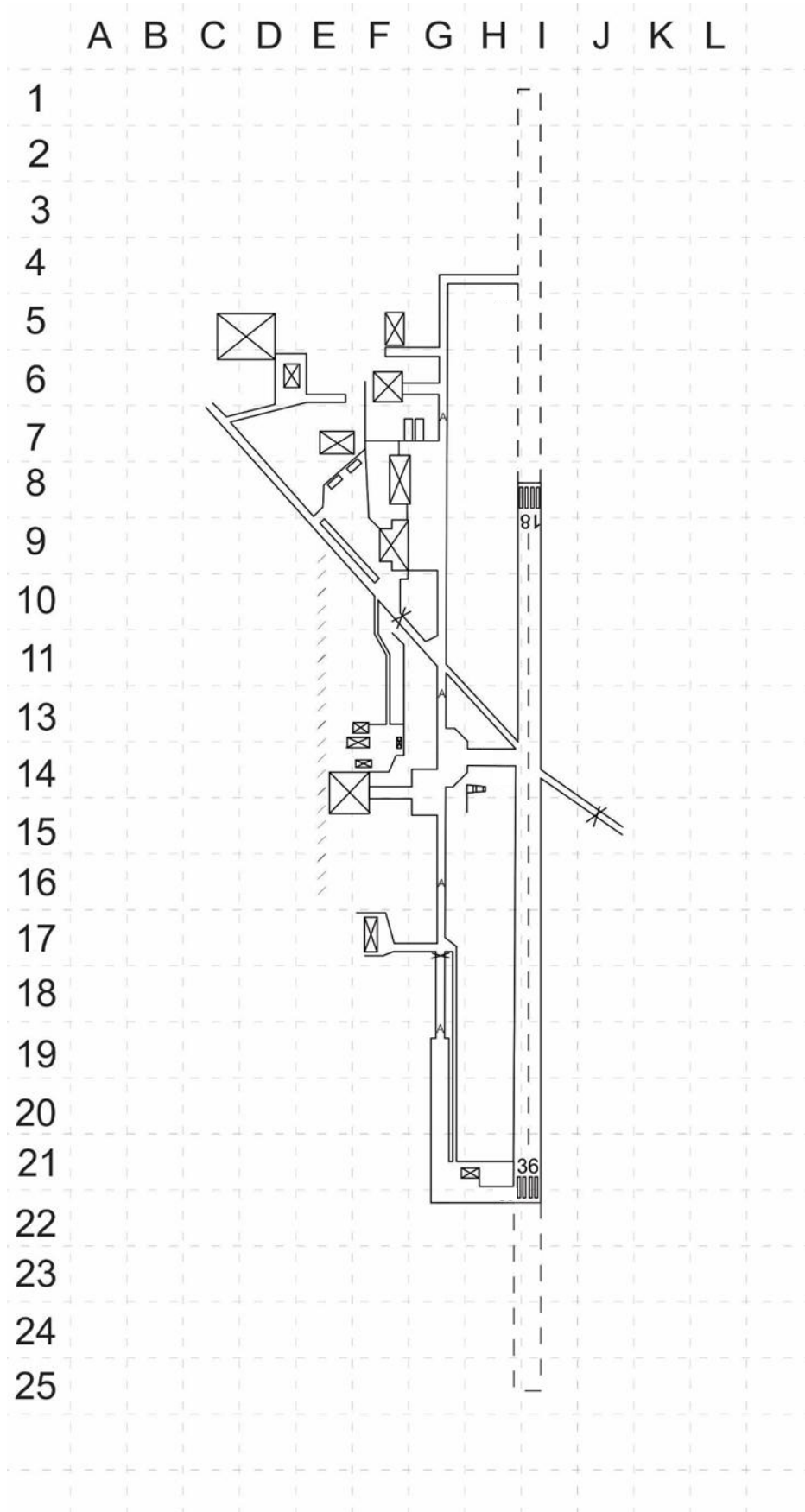

### 1.8.12 Designated Area

**Designated area at Jarlsberg**  
Staying in these areas requires authorization.

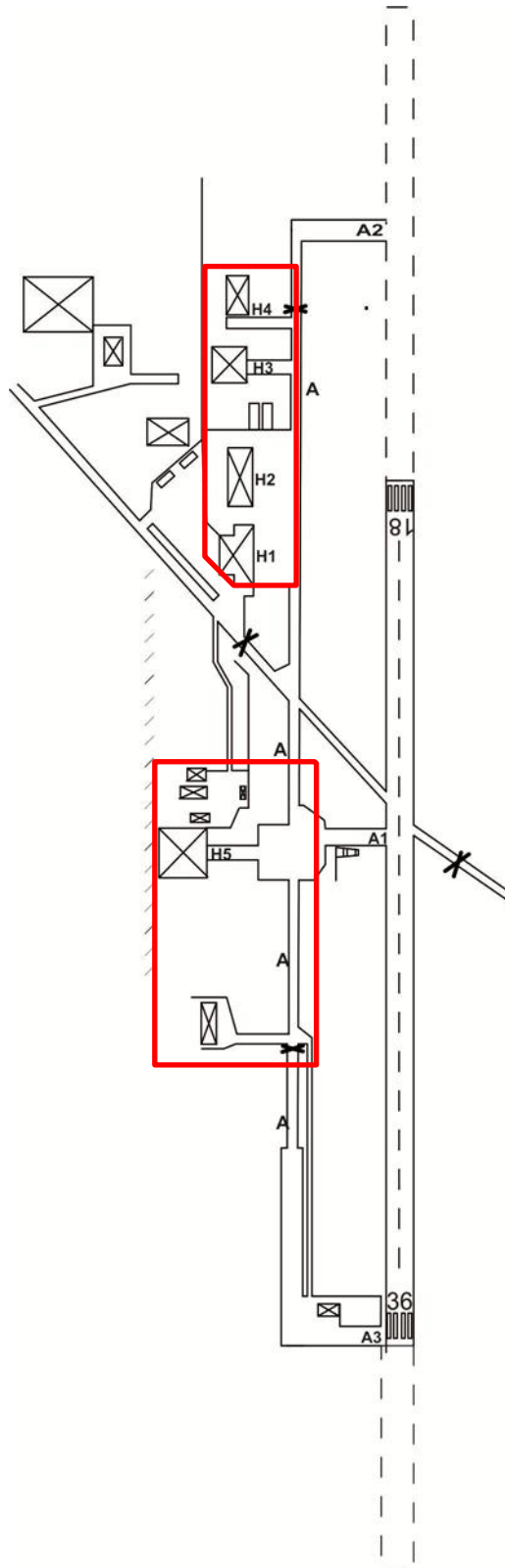



## 1.10.0 Attachments to operational manual

The content of the attachments will be subject to changes without further notice  
Contact JLS as for updated version.

### Jarlsberg Luftsportssenter AS

Flyplassveien 6  
N-3170 SEM  
Tlf +47 94 00 84 00

The following attachments could be located in this document:

- Clubs and companies located at Jarlsberg.
- Emergency response team
- Adress list
- Price list, JLS
- Schedule for internal control
- Letter of agreement between JLS ENTO og Torp TWR (Norwegian only)

### 1.10.1 Clubs / companies holding an agreement for the use of Jarlsberg

- Tønsberg Flyveklubb
- Tønsberg Seilflyklubb
- Tønsberg Modellflyklubb
- Tønsberg Fallskjermklubb
- Jarlsberg Sportsflyklubb

### 1.10.2 Emergency response team

<b>Bjørn S. Kristoffersen</b>	Rambergveien 15B 3115 Tønsberg	94008400	JLS
Roe Nerem	Wergelandsvei 2 3117 Tønsberg	97174448	JLS
Tor H Bjørnsund	Arne Beckersgt. 67, 3188 Horten	91135588	TøFSK

### 1.10.3 Address and telephone numbers

<b>AMBULANCE</b>	Medical emergencies	<b>113</b>
<b>Fire Department</b>	Vestfold Fire Department	<b>110</b>
<b>Heli Ambulance</b>		<b>113</b>
<b>POLICE</b>	Tønsberg	<b>112</b>
<b>Airfield Manager</b>	Bjørn Schjøll Kristoffersen	<b>940 08 400</b>
Deputy Airfield manager	Tor Heggernes Bjørnsund	911 35 588
Jarlsberg Luftsportssenter AS	Flylassveien 6 3170 Sem.	post@enjb.no
Tønsberg Flyveklubb (TFK)	Flylassveien 6 3170 Sem.	
Tønsberg Seilflyklubb (TSFK)	Flylassveien 6 3170 Sem.	
Tønsberg Modellflyklubb (TMFK)	Flylassveien 6 3170 Sem.	
Tønsberg Fallskjermklubb (TøFSK)	Flylassveien 6 3170 Sem.	
Jarlsberg light sport aircraft (JSK)	Flylassveien 6 3170 Sem.	

#### **1.10.4 Pricelist Jarlsberg Luftsportssenter**

1. Electronic ID card andkey, kr 300.
2. Driving permit and electronic key, kr 300.
3. Landing fee kr. 200.
4. One year landing fee aircraft, kr. 3000.
5. Reissue of driving permit and electronic key kr 100.
6. Air show fee to be determined by JLS as.

One year landing fee gives no right to do flight training and T&G for anyone without a fixed base at Jarlsberg.

***Payment.***

All fees are payable to: Jarlsberg Luftsportssenter AS  
Flyplassveien 6  
3170 Sem.  
Bank account no. **1503.45.66191.**  
Please state the type of fee..

## 1.10.6 User declaration and legal disclaimer

### USER DECLARATION for Tønsberg Airfield Jarlsberg (ENJB)

Name \_\_\_\_\_  
Capital letters

Adress \_\_\_\_\_  
Capital letters

Date of birth \_\_\_\_\_

Email \_\_\_\_\_

Phone \_\_\_\_\_

Club or Activity \_\_\_\_\_

I hereby declare that I have read the current rules for operations at ENJB, and have accepted all the rules and limitations therein. I also declare that I would follow and obey those rules to my best ability. I also declare that I am aware of the fact that Tønsberg airfield do not fulfill the regulations concerning fire and rescue servise that apply to airpanes with a takeoff weight (MTOW) abow 5700Kg or more than 9 pax.

location and date: \_\_\_\_\_

Signatur: \_\_\_\_\_

This declaration is to be signed and delivered to JLS before any activity commences.

JFS AS  
Flyplassveien 6  
3170 Sem

For questions contact:

Airfield manager	940 08 400
General manager	971 74 448